



## **BENZINLARNING FRAKSION TARKIBINI ANIQLASH VA TAHLIL QILISH**

**Odilov Khayrullo Rakhmonjon o'g'li**

“Transport vositalari muhandisligi” kafedrası assistenti  
Andijon Mashinasozlik instituti, Andijon shahri, O'zbekiston.

E-mail: hayrulloodilov94@gmail.com

<https://doi.org/10.5281/zenodo.7294011>

Benzinlarning asosiy fizik - kimyoviy xossalariга zichlik, qovushqoqlik, bug'lanuvchanlik va to'yingan bug' bosimi xossalari kiradi.

Benzinlarning zichligi yonilg'ining karbyuratsiyalanish xossalariга ta'sir ko'rsatadi. Benzinning zichligi qancha katta bo'lsa, uning sirt tarangligi shuncha kata bo'ladi, benzin plyonkasi hosil bo'ladi, yonilg'i bug'lanishi qiyinlashadi. Neftdan olingan barcha yonilg'ilar turli qaynash haroratiga ega bo'lgan uglevodorodlarning murakkab aralashmasidir [1,2].

Masalan, benzin 35-205 °C gacha, dizel yonilg'isi esa, 170-350 °C haroratda qaynaydi. Yonuvchi aralashmaning sifati benzinning bug'lanish darajasiga bog'liqdir. Benzinning eng muxim xususiyati uning bug'lanish xususiyatidir [3,4,5].

Benzinning bu xossasi yonuvchi aralashmaning sifati xaqida fikr yuritish imkonini beradi. Suyuqlikning bug'lanishi jarayoniga uning qovushqoqligi, zichligi, yuza tarangligiga ta'sir ko'rsatadi. Benzin ko'p fraksiyali suyuqlikdir. Shu sababli uning muayyan qaynash harorati bo'lmaydi. Benzin tarkibida yengil fraksiyalar atmosfera bosimi ta'sirida 30-40 °C qaynay boshlaydi. Og'ir fraksiyalar esa 160-205 °C dagina qaynaydi [6,7,8,9].

Benzinning fraksion tarkibiga qarab, dvigatelni tez o't olishi, unig to'liq quvvat bilan ishlashi, chiqindi gazning zaharliligi va boshqa ko'rsatkichlarni bilib olish mumkin. Qishda yurgizib yuborish oson bo'lishi uchun yozgi va qishki benzinlar ishlab chiqariladi [10,11]. Qishki benzinlar fraksion tarkibining yengilligi bilan farq qiladi. Benzinning fraksion tarkibi maxsus xaydash asbobida aniqlanib, uning xaydalgan miqdori bilan xaydash harorati orasidagi bog'lanishni ko'rsatadi. Benzinning fraksion tarkibi quyidagi xaydash harorati: xaydashning boshlanish harorati, -10, -50, -90%; qaynashni tugatish harorati bilan baxolanadi [12,13,14,15,16]



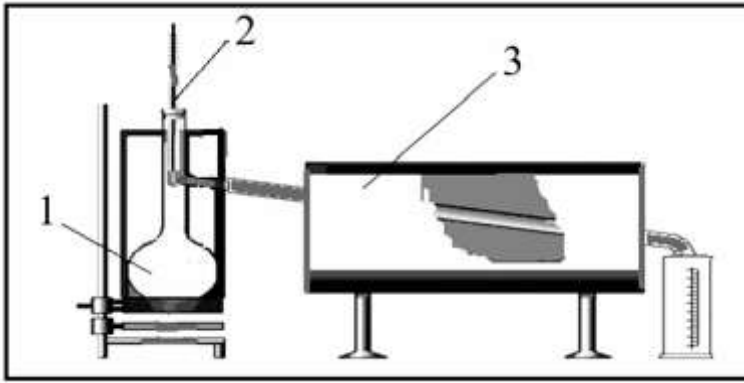

1-rasm. Yonilg'ilarni fraksion tarkibini aniqlaydigan qurilma.

1-xaydash kolbasi; 2-termometr; 3-sovitish asbobi.

### Fraksion tarkibni aniqlash quyidagi ketma-ketlikda amalga oshiriladi:

1. Tekshiriladigan yonilg'idan 100 ml o'lchab olinadi va xaydash kolbasiga solinadi. Kolbaga yog'och po'kakli tiqinlar orqali termometr o'rnatiladi [17,18,19,20,21].
2. Kolbani isitgich plita ustiga shunday o'rnatiladiki, kolbaning tagi isitgich ustidagi asbestga xiyol tegib turadi. Kolbaning yonboshidagi trubkasi sovitgichga tiqinlar yordamida mahkamlanadi [22,23,24,25];
3. O'lchov silindri sovitgich trubkasining tugash yeriga qo'yiladi, silindrni ustini paxta yoki yupqa qog'oz bilan yengil berkitib qo'yiladi;
4. Isitish shunday olib boriladiki, sovitgichdan birinchi tomchi qizdirish boshlanganidan 5-10 minut orasida tushishi kerak. Birinchi tomchining tushgan harorati xaydashning boshlanish harorati deb qabul qilinadi [26,27,28,29,30];
5. Birinchi tomchi tushgandan so'ng, isitishni shunday olib boriladiki 1 sekund ichida 2 tomchi tushib turishi kerak. O'lchash oson bo'lishi uchun sovitgich trubkasi silindr devoriga tegizib turishi lozim [31,32,33,34,35];
6. Har 10 ml. yonilg'i xaydalganda harorat yozib boriladi. Xaydash tezligi bir xilda bo'lishi uchun borgan sari isitishni biroz ko'paytirib boriladi [36,37,38];
7. Silindrda 90 ml. yonilg'i yig'ilgandan so'ng 3-5 minut orasida xaydash tugallanishi kerak;
8. Xaydashni tugallanish harorati deb, haroratni maksimumga ko'tarilib so'ng pasayish payti olinadi. Shundan so'ng isitish to'xtatiladi va umumiy xaydalgan yonilg'i miqdori o'lchanadi [23,24,25,26];
9. Xaydash tugallangandan keyin bir oz vaqt o'tgach kolba sovigandan so'ng asbob yig'ishtiriladi, yonilg'ining kolbada qolgan qismi kichikroq o'lchash asbobida o'lchanadi va qoldiq sifatida yozib qo'yiladi;
10. Yonilg'ining xaydalgan qismi va qoldiq miqdori birgalikda umumiy hajmi (100 ml.) dan ayirib tashlansa yonilg'ining xaydash vaqtida yo'qolgan qismi



topiladi. Mana shu yo'qolgan qismi benzin tarkibida yengil bug'lanuvchi fraksiyasiga bog'liq;

11. Olingan natijalarni jadvalga kiritiladi va xulosa beriladi. Quyidagi jadvalda qishki va yozgi AI-80 benzinning fraksion tarkibi aniqlangan [4,33,34,35]

1-jadval.

**BENZINLARNING FRAKSION TARKIBI JADVALI**

BH	Tegishli harorat, °C										Qoldiq, %	Yo'qo-tish, %
	10 %	20 %	30 %	40 %	50 %	60 %	70 %	80 %	90 %	OH 96,5%		
39	70	83	95	108	115	125	135	150	172	193	1,4	2,1

**Foydalanilgan adabiyotlar ro'yxati:**

[1] Каримходжаев Н., Алматаев Т. О., Одилов Х. Р. У. Основные причины, вызывающие износ деталей автотранспортных средств, эксплуатирующихся в различных природно-климатических условиях //Universum: технические науки. – 2020. – №. 5-1 (74). – С. 68-71.

[2] Odilov X. R. O. G. L. Analyze the efficiency of alternative fuels //Science and Education. – 2022. – Т. 3. – №. 6. – С. 419-425.

[3] Икромов Н. А., Жалолова З. Х. Исследования адгезионная прочность полимерных покрытий обработанных в магнитном поле //SO'NGI ILMIY TADQIQOTLAR NAZARIYASI. – 2022. – Т. 1. – №. 4. – С. 58-62.

[4] Икромов Н. А., Расулов Д. Н. Объекты и методики исследования композиционных полимерных материалов //Современные научные исследования и инновации. – 2020. – №. 10. – С. 1-1.

[5] Икромов Н. А. Исследования физико-механических свойств радиационно модифицированных эпоксидных композиций и покрытий на их основе //Universum: технические науки: электрон. научн. журн. – 2021. – Т. 12. – С. 93.

[6] Ikromov N. A., Turaev S. A. To determine the ingesting of various polymer materials of automobile cartridges //Academia-an international multidisciplinary research journal. – Т. 10.

[7] Б.Тожибоев, Н.А.Икромов Исследование свойств радиационно – обработанных наполненных композиционных полимерных покрытий у-лучами Universum: Технические науки Выпуск: Москва 12(81) декабрь 2020 г. 51-53 ст.





- [8] Ikromov N. A. et al. Situation of nes balance in the city passenger transportation market when moving passengers with transfers //Asian Journal of Multidimensional Research (AJMR). – 2020. – Т. 9. – №. 3. – С. 188-198.
- [9] Avazbekovich I. N. Application Of Composite Materials and Metal Powders in the Technology of Restoration of Worn Parts //Texas Journal of Engineering and Technology. – 2022. – Т. 9. – С. 70-72.
- [10] Икромов Н. А., Гиясидинов А. Ш., Рузиматов Б. Р. У. Меры по снижению экологического воздействия автопарка //Universum: технические науки. – 2021. – №. 4-1 (85). – С. 44-47.
- [11] О.Хамракулов, З.Х.Алимова, М.Х.Рахматуллаев – Транспорт воситаларида ишлатиладиган эксплуатацион материаллар, Жиззах-2004
- [12] Z.X.Alimova-Transport vositalarida ishlatiladigan ekspluatatsion materiallar, Toshkent - «Fan va texnologiya» - 2011.
- [13] Rahmonov X., Odilov X. Organization of quality transport service //Asian Journal of Multidimensional Research. – 2022. – Т. 11. – №. 5. – С. 289-293.
- [14] Икромов Н. А. Исследование влияния магнитного поля на физикомеханические свойства композиционных полимерных покрытий //Вестник Курганского государственного университета. – 2015. – №. 3 (37). – С. 96-99.
- [15] Икромов Н. А. Исследования физико-механических свойств радиационно модифицированных эпоксидных композиций и покрытий на их основе //Главный редактор: Ахметов Сайранбек Махсутович, д-р техн наук; Заместитель главного редактора: Ахмеднабиев Расул Магомедович, канд. техн. наук; Члены редакционной коллегии. – 2021. – С. 59.
- [16] Muqimova D., Nurdinov M. Compliance with responsibility and work regimes of drivers in legal regulatory documents due to accidents in the transportation of international goods by trucks //Theoretical aspects in the formation of pedagogical sciences. – 2022. – Т. 1. – №. 2. – С. 15-25.
- [17] Turaev S. The role of polymer materials used in the development of automobile industry //Asian Journal of Multidimensional Research. – 2022. – Т. 11. – №. 5. – С. 284-288.
- [18] Shukurov M. M. et al. Roads, road lines and thermoplastic products used in their drawing //ACADEMICIA: An International Multidisciplinary Research Journal. – 2021. – Т. 11. – №. 4. – С. 258-263.
- [19] Kholmatov U. The possibility of applying the theory of adaptive identification to automate multi-connected objects //The American Journal of Engineering and Technology. – 2022. – Т. 4. – №. 03. – С. 31-38.



- [20] MUQIMOVA D. K. et al. Analysis of the Current State of Population Growth and Level of Vehicle Ownership //Texas Journal of Engineering and Technology. – 2022. – Т. 13. – С. 22-28.
- [21] Omadjon M., Xasanboy T. Weight distribution of the machine-tractor unit when lifting universal power equipment //Universum: технические науки. – 2022. – №. 4-11 (97). – С. 60-63.
- [22] Mamasoliyev, B., Ismoilov, S., Abdusattarov, N., Arabboyev, R., & Boqiyev, O. (2022). Elimination of noisy operation of damas rear suspensions. Science and innovation in the education system, 1(4), 59-63.
- [23] Erkinjonov A. et al. Operating conditions of transport vehicles //Theoretical aspects in the formation of pedagogical sciences. – 2022. – Т. 1. – №. 4. – С. 32-33.
- [24] Рахмонов Х. Н., Исмаилов С. Т., Амиржонов А. А. Структурный анализ нового дифференциального передаточного механизма с симметричным перемещением центров вращения ведущих и ведомых зубчатых колес и его модификации //Universum: технические науки. – 2021. – №. 4-1 (85). – С. 56-59.
- [25] Toxir og'li T. X. et al. Analysis of Engine and Engine Technical Condition, Fuel Consumption and Effects on Gas Emissions //JournalNX. – Т. 8. – №. 6. – С. 78-82.
- [26] Нурдинов М. и др. БЕЗОПАСНЫЕ ПАРКОВОЧНЫЕ МЕСТА ДЛЯ МЕЖДУНАРОДНЫХ ГРУЗОВИКОВ МЕТОД УПРАВЛЕНИЯ НА ТРАНЗИТНЫХ ДОРОГАХ //Models and methods in modern science. – 2022. – Т. 1. – №. 15. – С. 148-157.
- [27] Bakirov L. et al. GUARANTEE SAFE MOVEMENT BY DESIGNING DRIVER'S WORK MODE THROUGH VEHICLE KEY IN ORGANIZING INTERNATIONAL TRANSPORTATION. – 2022.
- [28] Мамаев Г. И., Бакиров Л. Ю. ПРОБЛЕМЫ УЛИЧНЫХ ПАРКОВОК И ЗАРУБЕЖНЫЙ ОПЫТ ОРГАНИЗАЦИИ ПАРКОВОК.
- [29] Ziyamukhamedova U. A. et al. Improvement of methods and means of testing non-conventional tribosystems //AIP Conference Proceedings. – AIP Publishing LLC, 2022. – Т. 2432. – №. 1. – С. 030031.
- [30] Anti-Corrosion Coatings for Large-Size Technological Equipment of Oil Refining and Cotton-Processing Production  
UA Ziyamukhamedova, LY Bakirov, H Makhsudova - International Journal of Advanced Research in Science ..., 2020



[31] ZIYAMUKHAMEDOVA U. A. et al. INVESTIGATION OF INFLUENCE OF FILLERS ON THE PROPERTIES OF COMPOSITE POLYMERIC MATERIALS OBTAINED WITH THE USE OF SOLAR ENERGY //CHEMISTRY AND CHEMICAL ENGINEERING. – 2018. – Т. 2018. – №. 2. – С. 7.

[32] U.A.Ziyamuxamedova, M.A.Nurdinov, L.Y.Bakirov MASHINASOZLIKDA QO'LLANILADIGAN POLIFUNKSIONAL GETEROKOMPOZIT POLIMER MATERIALLAR UCHUN BOG'LOVCHI TO'LDIRUVCHILARNI TANLASH VA ASOSLASH // ORIENSS. 2021. №4. URL: <https://cyberleninka.ru/article/n/mashinasozlikda-qo-llaniladigan-polifunksional-geterokompozit-polimer-materiallar-uchun-bog-lovchi-to-ldiruvchilarni-tanlash-va> (дата обращения: 29.10.2022).

[33] Nozimbek A., Kongratbay S., Khasanboy T. MANUFACTURE OF AUTOMOTIVE PLASTIC PARTS UNDER PRESSURE AND THE FACTORS AFFECTING IT //Universum: технические науки. – 2021. – №. 3-4 (84). – С. 56-59.

[34] ANALYSIS OF THE GROWTH OF EXISTING TRANSIT ROUTES IN THE REPUBLIC OF UZBEKISTAN AND THE DUPLICATION OF HIGHWAYS IN TRANSIT ROUTES (<https://researchcitations.com/index.php/ibast/article/view/158>) M Nurdinov, A Erkinjonov - 2022 - researchcitations.com IB M SC R IBA ST INTERNATIONAL BULLETIN OF APPLIED SCIENCE AND TECHNOLOGY Page 1 IB M SC R | Volume 2, Issue 8, August IBA ST | Volume 2, Issue 10, October 159 ...

[35] Kholmiraev J., Kuchkorov I., Kakhkharov A. DETERMINING THE NEED FOR SPARE PARTS FOR SPECIAL VEHICLES OPERATING AT AIRPORTS //Central Asian Academic Journal of Scientific Research. – 2022. – Т. 2. – №. 5. – С. 208-211.

[36] Mahammadjonov N. et al. YO 'L FREZASI KONSTRUKSIYASINING TAHLILI //Science and innovation in the education system. – 2022. – Т. 1. – №. 5. – С. 45-49.

[37] Беккулов Б. Р., Рахмонкулов Т. Б. Исследования движения шала в сушильном барабане //НАУКА РОССИИ: ЦЕЛИ И ЗАДАЧИ. – 2021. – С. 88-92.

[38] D. Zokirov, G. Ismoilova TRASSANING SUVGA TO'YINGAN UCHASTKALARIDA YOTQIZILADIGAN YER OSTI QUVURO'TKAZGICHLARINI HISOBLASH // SAI. 2022. №6. URL: <https://cyberleninka.ru/article/n/trassaning-suvga-to-yingan-uchastkalarida-yotqiziladigan-yer-osti-quvuro-tkazgichlarini-hisoblash> (дата обращения: 14.10.2022).